

In-Line mixers

Silverson High Shear mixers are supremely efficient and rapid in operation and are capable of reducing mixing times by up to 90%.

The action of any Silverson In-Line mixer can be modified with the use of rapidly interchangeable workheads. This enables any machine to mix, emulsify, homogenise, solubilise, suspend, disperse and disintegrate solids.

- Aeration free
- Self-pumping
- No bypassing
- Interchangeable workheads
- Hygienic construction
- Easy maintenance
- Lower power requirements
- Eliminates agglomerates and fish eyes
- Creates stable emulsions and suspensions
- Reduces particle size
- Rapidly dissolves solids
- Accelerates reactions



How the In-Line works

Stage 1

The high speed rotation of the rotor blades within the precision machined mixing workhead exerts a powerful suction, drawing liquid and solid materials into the rotor/stator assembly.

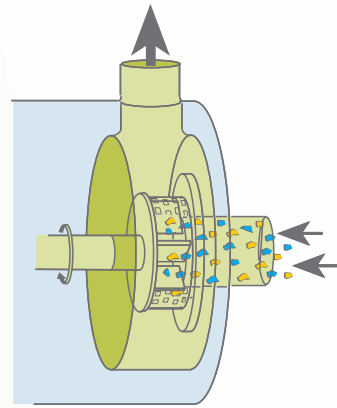

Stage 2

Centrifugal force then drives materials towards the periphery of the workhead where they are subjected to a milling action in the precision machined clearance between the ends of the rotor blades and the inner wall of the stator.

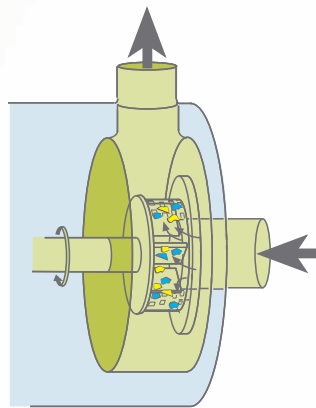

Stage 3

This is followed by intense hydraulic shear as the materials are forced, at high velocity, out through the perforations in the stator, then through the machine outlet and along the pipework. At the same time, fresh materials are continually drawn into the workhead, maintaining the mixing and pumping cycle.

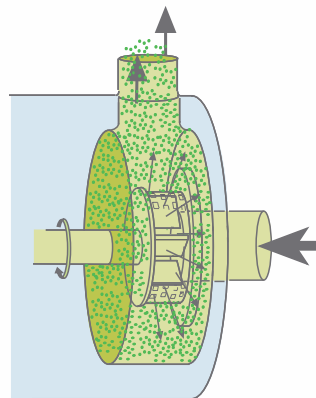

Ultra Hygienic In-Line mixers

The Silverson Ultra Hygienic series of multipurpose In-Line mixers is able to perform the widest variety of applications - mixing, emulsifying, homogenising, disintegrating and dissolving - with an efficiency, flexibility and hygienic construction unmatched by other machines.

EHEDG Certified and designed to comply with **FDA, 3A** and **cGMP** guidelines, these machines are ideally suited for industries where advanced Clean-In-Place (CIP) and Sterilise-In-Place (SIP) facilities are required. The design offers further versatility with multistage rotor/stator configurations as standard options, resulting in substantially faster mixing times by reducing the number of recirculation passes required, and offering greater particle size reduction.

Features:

- Interchangeable workheads with single or multistage configurations
- Ultra Hygienic **EHEDG** Approved single mechanical shaft seals, easily converted to Ultra Hygienic **EHEDG** Approved double mechanical shaft seals
- Outlet can be configured for self-venting vertical outlet or rotated to tangential self-draining position
- Designed for Clean-In-Place (CIP) and Sterilise-In-Place (SIP) operation
- Self-pumping
- Aeration free
- Crevice-free construction
- No metal-to-metal contact
- No castings - no porosity
- All 316L stainless steel construction of wetted parts
- No manual dismantling and cleaning is required, significantly reducing maintenance, operating costs, increasing reliability and increasing productivity

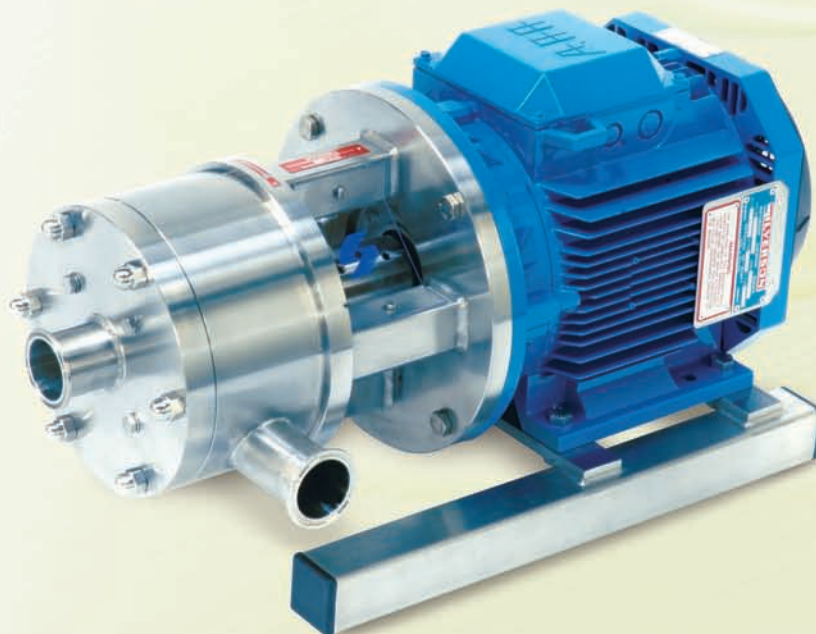

Advantages

Hygienic construction

EHEDG Certified and designed to comply with **FDA, 3A** and **cGMP** guidelines, these machines are ideally suited for industries where Cleaning In Place (CIP) procedures are the norm. Not only do these include the food, pharmaceutical and cosmetic industries, but also more diverse applications where modern manufacturing techniques and maximum equipment utilisation require a rapid changeover from one product to another.

Interchangeable workheads

Available to adapt the machine for varying processes. Changing from one head or screen to another is quick and simple.

Speed

Adding a Silverson In-Line mixer to an existing process can cut mixing times by up to 90% compared with conventional agitators and mixers.

No by-passing

The In-Line mixer's design makes it physically impossible for any materials - liquid or solid - to pass from the inlet to the outlet without being subjected to intense mechanical and hydraulic shear as it passes through the rotor/stator workhead. By-passing is impossible.

Aeration free

As the In-Line mixer and associated vessel and pipework form a closed system, the mixing process is completely aeration free. This is particularly important for applications where air entrainment creates a problem.

Lower power requirements

As the mixer's energy is concentrated on processing the small volume of material inside the workhead at any given moment, power is not wasted moving large volumes of liquid and consequently less power is normally required than for the equivalent batch mixer. This is particularly beneficial when processing large volumes of material.



How to use the In-Line mixer

Recirculation method

This is the most common way of using an In-Line mixer, providing a higher degree of homogenisation and particle size reduction. Here product is drawn from the bottom of the vessel, processed through the high shear rotor/stator workhead and passed back into the top of the vessel.

In small vessels this will ensure adequate in-tank movement but in larger vessels an auxiliary in-tank mixer or agitator will be required.

Additional fluid ingredients can be fed into the workhead and uniformly mixed before entering the vessel.

Where quality assurance (QA) demands a set number of passes through the rotor/stator workhead, product can be passed back and forth between two separate vessels.

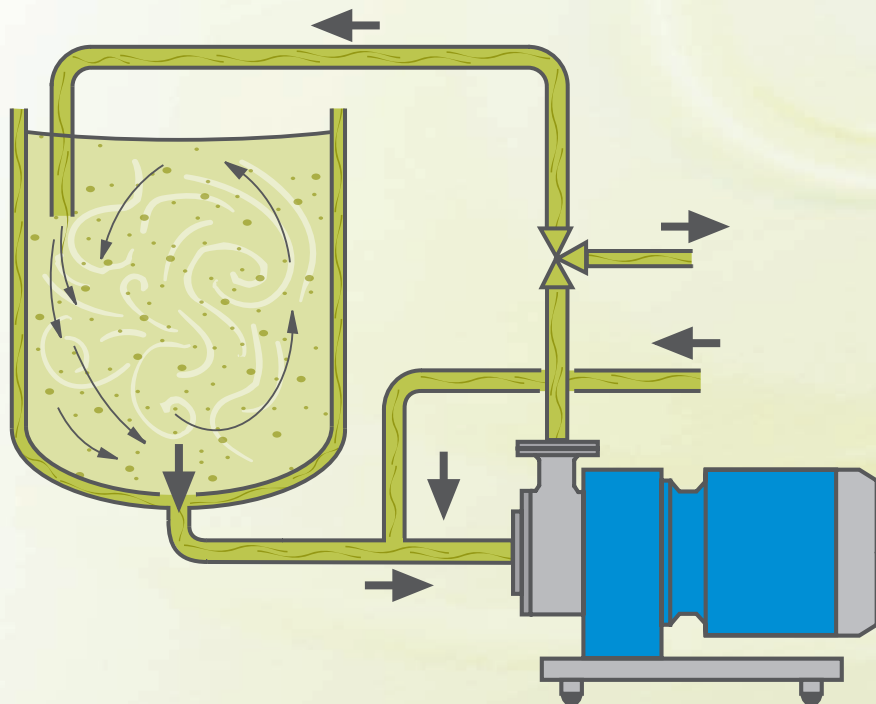

Single pass method

There are basically three types of operations for which single pass processing can be used.

Continuous blending

Ingredients are metered into the mixer or a manifold just prior to the rotor/stator workhead. This ensures that products that react together are mixed immediately on contact. This method is ideal for continuous liquid/liquid blending and for products where aeration must be avoided, e.g. detergents.

Series processing

In cases where a higher degree of homogenisation or comminution is required than can be obtained by a single pass through the In-Line mixer, it is possible to achieve the required results by using two or more machines in series.

Premix method

The ingredients are coarsely premixed in a holding vessel with a Silverson Batch mixer, Ultramix or a simple agitator. A single pass through the In-Line mixer will then ensure an agglomerate-free homogeneous product. All the product must pass through the In-Line mixer's rotor/stator workhead as by-passing is impossible.

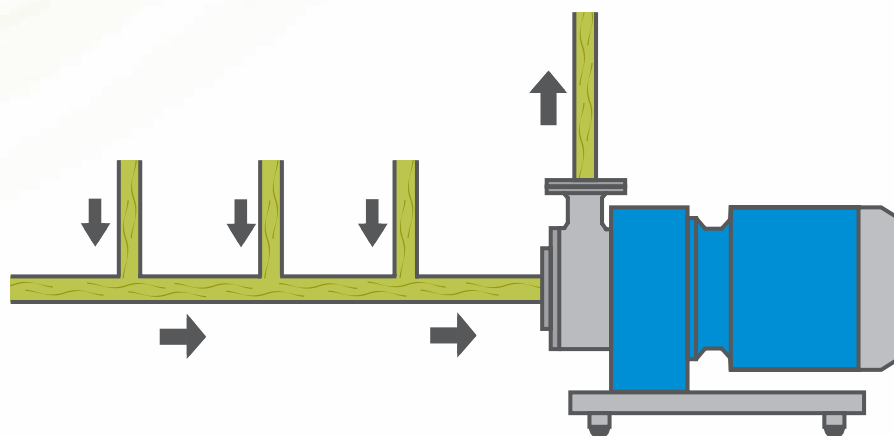

Technical specifications

Materials of construction

Product contact parts in 316L Stainless Steel. Special materials on request.

Motors

TEFV (Totally enclosed Fan Cooled) and ATEX approved Flameproof motors are available as standard. Inverter rated, stainless steel and other motors are available as optional extras.

Operating pressures

All Hygienic Multipurpose models are designed for operation on pressures of up to 150 psi (10 bar). Higher pressure units are available on request.

Inlet and outlet connections

All standard sanitary screw or flange fittings are available on request (e.g. ISS, DIN, RJT, SMS, Tri-clamp, etc.).

Interchangeable workheads

Single stage rotor/stator configurations as standard. For those applications which require greater shear, interchangeable multistage configurations can be used.



General purpose disintegrating head



General Purpose Disintegrating Head, Multistage Inner and Outer



Slotted disintegrating head



Slotted Disintegrating Head, Multistage Inner and Outer



Square hole high shear screen™



Combined Configuration: Inner General Purpose with Outer Slotted Disintegrating Head



Emulsor screen



Combined Configuration: Inner Slotted with Outer Square Hole High Shear Screen™

General duty In-Line mixers

Silverson offers a range of In-Line mixers suitable for hazardous and aggressive chemical service.

These units are of robust and simple construction which ensures that maintenance is easy and downtime minimal.

With some of the highest rotor tip speeds and shear rates in the industry, production times can be cut by up to 90%, reducing mechanical wear and maintenance requirements while offering better particle size reduction, emulsification, rapid solubilisation and dispersion.

Optional features

- Jacketed units for temperature sensitive products
- Non-standard materials of construction such as hastelloy, titanium and hardened steels for processing highly abrasive or corrosive products
- High capacity units with self-pumping capacities from 220 litres up to 300,000 litres per hour

Typical Applications

Bitumens, Edible oil refining, Drilling Muds, Adhesives, Luboils, Pigment dispersions, Titanium dioxide, etc.

